



**EMC COMPLIANCE TEST REPORT
FOR
Prof Revolution S2 8000 PCI-E**

Trade Name : N/A
Model Number : Prof8000
Serial Number : N/A
Report Number : GSI10042960803
Date : May 07, 2010
Regulations : See below

Standards	Results (Pass/Fail)
EN 55013:2001+A1: 2003+A2: 2006	PASS
EN 61000-3-2:2006	N/A
EN 61000-3-3:2008	N/A
EN 55020:2007	PASS
(EN 61000-4-2:2009	PASS
EN 61000-4-3:2006	PASS
EN 61000-4-4:2004)	N/A

Issued to:

**HongKong Tenow International Ltd.
Unit C-8A, Shennan Garden Building, High-Tech Park, Nanshan
District, Shenzhen, China**

Issued by:

**Shenzhen GSI Electronic Technology Co.,Ltd.
Room 929, XianKeJiDian Building, BaGuaSi Road, Shenzhen, China**

**TEL: 86-755-25844177
FAX: 86-755-25844877**

Note: This report shall not be reproduced except in full, without the written approval of GSI Electronic Technology Co., Ltd. This document may be altered or revised by GSI Electronic Technology Co., Ltd. Personnel only, and shall be noted in the revision section of the document.



2 CONTENTS

Test Report Declaration		Page
1	COVER PAGE	1
2	CONTENTS	2
3	TEST RESULT CERTIFICATION	3
4	GENERAL INFORMATION	4
7	SUPPORT EQUIPMENT	7
8	TEST FACILITY	8
9	EQUIPMENT USED DURING TEST	9
10	POWER LINE CONDUCTED EMISSION MEASUREMENT	10
	10.1 Preliminary Power Line Conducted Emission Test.....	10
	10.2 Final Line Conducted Emission Test.....	11
	10.3 Block Diagram of Test Setup.....	12
	10.4 Summary Data.....	12
11	ANTENNA POWER CONDUCTED EMISSION MEASUREMENT	13
	11.1 Block Diagram of Test Setup.....	13
	11.2 ANTENNA Power Conducted Measurement Limits.....	13
	11.3 Configuration of EUT on Measurement.....	13
	11.4 ANTENNA Power Conducted Measurement Results.....	14
12	RADIATED EMISSION	15
	12.1 Preliminary Radiated Emission Test.....	15
	12.2 Final Radiated Emission Test.....	16
	12.3 Block Diagram of Test Setup.....	17
	12.4 Summary Data.....	18
13	HARMONIC CURRENT EMISSION TEST	19
	13.1 POWER HARMONICS MEASUREMENT.....	19
	13.2 Block Diagram of Test Setup.....	19
	13.3 Result:.....	19
14	VOLTAGE FLUCTUATION/FLICKER	20
	14.1 VOLTAGE FLUCTUATION/FLICKER MEASUREMENT.....	20
	14.2 Block Diagram of Test Setup:.....	20
	14.3 Result:.....	20
15	ELECTROSTATIC STATIC DISCHARGE TEST	21
	15.1 ELECTROSTATIC DISCHARGE (ESD) IMMUNITY TEST.....	21
	15.2 Block Diagram of Test Setup.....	21
	15.3 Severity Levels and Performance Criterion.....	21
	15.4 Test Procedure.....	22
	15.5 Performance & Result:.....	22
16	RADIATED ELECTROMAGNETIC FIELD	24
	16.1 Radiated Electromagnetic Field Immunity Test.....	24
	16.2 Block Diagram of Test Setup.....	24
	16.3 Test Procedure.....	25
	16.4 : Performance & Result.....	25
17	FAST TRANSIENTS/BURST	26
	17.1 Fast Transients/Burst Immunity Test.....	26
	15.2 Block Diagram of Test Setup.....	26
	17.2 Test Procedure.....	27
	17.3 Performance & Result:.....	27
	APPENDIX I- RADIATED EMISSION TEST DATA	28
	APPENDIX II- RADIATED EMISSION TEST DATA	30
	APPENDIX III- RADIATED EMISSION TEST DATA	32



3 TEST RESULT CERTIFICATION

Equipment Under Test : Prof Revolution S2 8000 PCI-E
Trade Name : N/A
Model Number : Prof8000
Series Number : N/A
Applicant : HongKong Tenow International Ltd.
Unit C-8A, Shennan Garden Building, High-Tech
Park, Nanshan District, Shenzhen, China
Manufacturer : Same as applicant
Type of Test : EMC Directive 2004/108/EC for CE Marking
Technical Standards : EN 55013:2001 +A1: 2003+A2: 2006
EN 61000-3-2:2006,
EN 61000-3-3:2008
EN 55020:2007
(EN 61000-4-2:2009,EN 61000-4-3:2006,EN 61000-4-4:2004)

Report Number : GSI10042960803
Date of Test : April 29, 2010 to May 07, 2010
Deviation : None
Condition of Test Sample : Normal

The product described above is tested by Shenzhen Emtek Co., Ltd. The measurement results are contained in this test report and Shenzhen Emtek Co., Ltd assume full responsibility for the accuracy of the test results. Also, this report shows that the EUT (Equipment Under Test) technically complies with the council the EMC Directive 2004/108/EC requirements.

The test report is valid for above tested sample only and shall not be reproduced in part without written approval of Shenzhen GSI Electronic Technology Co., Ltd.

Prepared by :

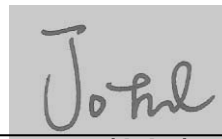
(John)

Approved & Authorized Signer:

(Morris)



4 GENERAL INFORMATION

Applicant : HongKong Tenow International Ltd.
Manufacturer : Same as applicant
Report Number : GSI10042960803
Date of Test : April 29, 2010 to May 07, 2010
Equipment under Test : Prof Revolution S2 8000 PCI-E
Model Number : Prof8000
Serial Number : N/A
Type of Test : EMC Directive 2004/108/EC for CE Marking
Technical Standards : EN 55013:2001+A1: 2003+A2: 2006
EN 61000-3-2:2006, EN 61000-3-3:2008
EN 55020:2007
(IEC 61000-4-2: 2009, EN 61000-4-3:2006, EN 61000-4-4:2004)

Frequency Range : 30MHz to 2150MHz for Antenna Power Measurement
(EN55013) 30MHz to 1000MHz for Radiated Emission Measurement.

Test Site : Shenzhen Emtek Co., Ltd
Bldg. 69, Majialong, Taipinyang Industry Zone, Nanshan District,
Shenzhen, Guandong



5 SYSTEM DESCRIPTION

EUT Test Program:

1. The EUT was connected to PC with 230V/50Hz.
2. Set up EUT with the relative support equipments and power on.
3. Make sure the EUT worked normally during the test.



6 PRODUCT INFORMATION

Input: DC5V from PC
Power Source during Test: AC 230V 50Hz power for PC



7 SUPPORT EQUIPMENT

No.	Equipment	Model#	Serial#	Trade Name	Data Cable	Power Cord
1	PC	Dx2700	CNG7710	HP	Unshielded, 1.8m	N/A
2	ATSC Digital Signal Generator	CS2326	7320018624	Creastar	Unshielded, 1.8m	N/A

****Note:** All the above equipment/cables were placed in worse case positions to maximize emission signals during emission test.

Grounding: Grounding was in accordance with the manufacturer's requirements and conditions for the intended use



8 TEST FACILITY

Location:	Bldg. 69, Majialong, Taipinyang Industry Zone, Nanshan District, Shenzhen, Guandong
Description:	There is one 3m semi-anechoic chamber(966) test sites and one line conducted labs for final test. There is one 3m semi-anechoic and the Line Conducted labs are constructed and calibrated to meet the FCC requirements in documents ANSI C63.4: 1992 and CISPR 22/EN 55022 requirements.
Site Filing:	A site description is on file with the Federal Communications Commission, 7435 Oakland Mills Road, Columbia, MD 21046.
Site Accreditation:	Accredited by CNAS, 2005.11.02 Accredited by TUV. 2008.3
Instrument Tolerance:	All measuring equipment is in accord with ANSI C63.4 and CISPR13 requirements that meet industry regulatory agency and accreditation agency requirement.

Ground Plane: Two conductive reference ground planes were used during the Line Conducted Emission, one in vertical and the other in horizontal. The dimensions of these ground planes are as below. The vertical ground plane was placed distancing 40 cm to the rear of the wooden test table on where the EUT and the support equipment were placed during test. The horizontal ground plane projected 50 cm beyond the footprint of the EUT system and distanced 80 cm to the wooden test table. For Radiated Emission Test, one horizontal conductive ground plane extended at least 1m beyond the periphery of the EUT and the largest measuring antenna, and covered the entire area between the EUT and the antenna. It has no holes or gaps having longitudinal dimensions larger than one-tenth of a wavelength at the highest frequency of measurement up to 1GHz.



9 EQUIPMENT USED DURING TEST

Antenna Terminals Disturbance Voltage Test						
Item	Test Equipment	Manufacturer	Model No	Serial NO.	Cal.Date	Due bate
1	Test Receiver	Rohde & Schwarz	ESCS30	8289851018	11-8-2009	10-8-2010
2	Matching network	Weinschel	1506A	PM203	11-8-2009	10-8-2010

ESD Test(61000-4-2)						
Item	Test Equipment	Manufacturer	Model NO	Serial NO	Cal.Date	Due bate
1	HAEFELY ESD TESTER	EM Test	PESD 1600	302105	11-8-2009	10-8-2010

Radiated Electromagnetic Field immunity Measurement(61000-4-3)						
Item	Test Equipment	Manufacturer	Model NO	Serial NO	Cal.Date	Due bate
1	Signal Generator	Maconi	2022D	119246/003	11-8-2009	10-8-2010
2	Power Amplifier	M2S	A00181/1000	9801-112	11-8-2009	10-8-2010
3	Power Amplifier	M2S	AC8113/ 800-250A	9801-179	11-8-2009	10-8-2010
4	Power Antenna	SCHAFFNER	CBL6140A	1240	11-8-2009	10-8-2010



10 POWER LINE CONDUCTED EMISSION MEASUREMENT

10.1 Preliminary Power Line Conducted Emission Test

- 1) The equipment was set up as per the test configuration to simulate typical actual usage per the user's manual. When the EUT is a tabletop system, a wooden table with a height of 0.8 meters is used and is placed on the ground plane as per EN55013 (see Test Facility for the dimensions of the ground plane used). When the EUT is floor-standing equipment, it is placed on the ground plane which has a 3-12 mm non-conductive covering to insulate the EUT from the ground plane.
- 2) Support equipment, if needed, was placed as per EN55013.
- 3) All I/O cables were positioned to simulate typical actual usage as per EN55013.
- 4) The test system with EUT received DC power from PC, through a Line Impedance Stabilization Network (LISN) which supplied power source and was grounded to the ground plane.
- 5) All support equipments received power from a second LISN, if any.
- 6) The EUT test program was started. Emissions were measured on each current carrying line of the EUT using a spectrum Analyzer / Receiver connected to the LISN powering the EUT. The LISN has two monitoring points: Line 1 (Hot Side) and Line 2 (Neutral Side). Two scans were taken: one with Line 1 connected to Analyzer / Receiver and Line 2 connected to a 50 ohm load; the second scan had Line 1 connected to a 50 ohm load and Line 2 connected to the Analyzer / Receiver.
- 7) Analyzer / Receiver scanned from 150 KHz to 30MHz for emissions in each of the test modes.
- 8) During the above scans, the emissions were maximized by cable manipulation.
- 9) The following test mode(s) were scanned during the preliminary test:

Preliminary Conducted Emission Test			
Frequency Range Investigated		150 KHz TO 30 MHz	
Mode of operation	Date	Data Report No.	Worst Mode
Connect to PC	2010-4-30	Prof8000 (L,N)	☒

Then, the EUT configuration and cable configuration of the above highest emission level were recorded for reference of final testing.



10.2 Final Line Conducted Emission Test

- 1) EUT and support equipment was set up on the test bench as per step 9 of the preliminary test.
- 2) A scan was taken on both power lines, Line 1 and Line 2, recording at least the six highest emissions. Emission frequency and amplitude were recorded into a computer in which correction factors were used to calculate the emission level and compare reading to the applicable limit. If EUT emission level was less -2dB to the A.V. limit in Peak mode, then the emission signal was re-checked using Q.P and Average detector.
- 3) The test data of the worst case condition(s) was reported on the Summary Data page.

Data Sample:

Freq. MHz	Read Level dBuV	Factor dB	Level dBuV	Limit dBuV	Over Limit dB	Reading Type (P/Q/A)	Line (L1/L2)
x.xx	42.95	0.55	43.50	73	-29.50	Q	L1

Freq. = Emission frequency in MHz
 Read Level = Uncorrected Analyzer/Receiver
 reading Factor = Insertion loss of LISN + Cable
 Loss
 Level = Read Level + Factor
 Limit = Limit stated in standard
 Over Limit = Reading in reference to limit
 P = Peak Reading
 Q = Quasi-peak Reading
 A = Average Reading
 L1 = Hot side
 L2 = Neutral side

Line Conducted Emission Limit

Frequency (MHz)	Limit(dBuV)	
	Q.P.(dBuV)	AVERAGE(dBuV)
0.15~0.5	66-56	59-46
0.5~5.0	56	46
0.5~30.0	60	50

****Note:** The lower limit shall apply at the transition frequency.



10.3 Block Diagram of Test Setup

1) Block diagram of connection between the EUT and simulators

EUT: Prof Revolution S2 8000 PCI-E
TRADE NAME: N/A
MODEL NUMBER: Prof8000

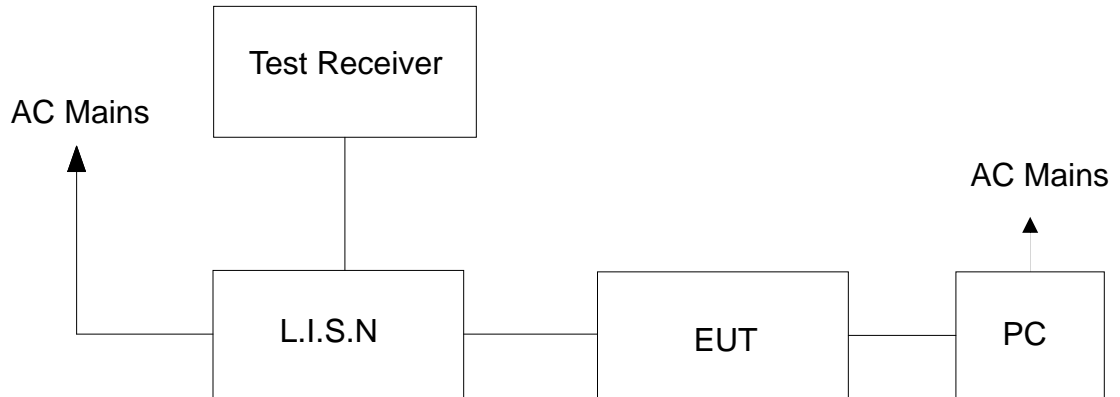

10.4 Summary Data

1) Line Conducted Test

Model Number: Prof8000

Location: Site 843

Test Mode: 230V AC Supply

Test Results: Passed

Temperature: 22°C

Humidity: 50%RH

This item is not applicable since the EUT is powered by DC5V.

11 ANTENNA POWER CONDUCTED EMISSION MEASUREMENT

11.1 Block Diagram of Test Setup

The following test equipments are used during the power line conducted measurement:

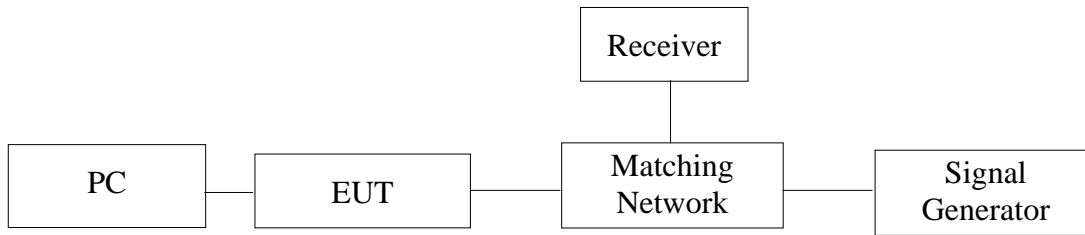

(EUT: Prof Revolution S2 8000 PCI-E)

11.2 ANTENNA Power Conducted Measurement Limits

The limit values specified correspond to a nominal impedance of 75 Ω, The limit values for receivers with nominal impedance other than 75 Ω are calculated according to the following formula:

$$LZ=L75+10\text{LOG}(Z/75) \text{ dB (uV)}$$

Equipment type	Source	Frequency	Limit values dB(uV) 75 Ω Quasi-peak ^a
Television receivers for broadcast satellite transmissions and tuner units	Local Oscillator	950 to 2150	Fundamental 54
	other	950 to 2150	Harmonics 54
		30 to 2150	46
a At frequencies above 1GHz the peak detector is used.			

11.3 Configuration of EUT on Measurement

- 1) EUT and support equipment were set up on the wooden table as per step 9 of the preliminary test.
- 2) The receiver scanned from 950MHz to 2150MHz.



11.4 ANTENNA Power Conducted Measurement Results

PASS.

The frequency range from 30 MHz to 2150MHz is investigated.

After the preliminary scan, we found the following test modes (DVB-S2) producing the highest emission level.

Date of Test	: 2010-4-30	Temperature	: 22°C
EUT	: Prof Revolution S2 8000 PCI-E	Humidity	: 50%
M/N	: Prof8000	Test Mode	: DVB-S2
Power Supply	: AC 230V/50Hz	Test Engineer	: JANE

Frequency MHz	Emission Level dBμV	Limits dBμV/75Ω	Margin dB
1550	44.9	54	-9.1
Remark: All readings are Peak values.			



12 RADIATED EMISSION

12.1 Preliminary Radiated Emission Test

- 1) The equipment was set up as per the test configuration to simulate typical actual usage per the user's manual. When the EUT is a tabletop system, a wooden turntable with a height of 0.8 meters is used which is placed on the ground plane as per EN55013 (see Test Facility for the dimensions of the ground plane used). When the EUT is floor-standing equipment, it is placed on the ground plane which has a 8-12 mm non-conductive covering to insulate the EUT from the ground plane.
- 2) Support equipment, if needed, was placed as per EN55013.
- 3) All I/O cables were positioned to simulate typical actual usage as per EN55013.
- 4) The EUT received DC 5V through the PCI power through the PC. All support equipments received power from socket under the turntable, if any.
- 5) The antenna was placed at 3 meter away from the EUT as stated in EN55013. The antenna connected to the Spectrum Analyzer via a cable and at times a pre-amplifier would be used.
- 6) The Analyzer / Receiver quickly scanned from 30MHz to 1GHz. The EUT test program was started. Emissions were scanned and measured rotating the EUT to 360 degrees and positioning the antenna 1 to 4 meters above the ground plane, in both the vertical and the horizontal polarization, to maximize the emission reading level.
- 7) The following test mode(s) were scanned during the preliminary test:

Preliminary Radiated Emission Test			
Frequency Range Investigated		30 MHz TO 1GHz	
Mode of operation	Date	Data Report No.	Worst Mode
DVB-S2	2010-4-30	Prof8000 (L,N)	<input checked="" type="checkbox"/>

Then, the EUT and cable configuration, antenna position, polarization and turntable position of the above highest emission level were recorded for final testing.



12.2 Final Radiated Emission Test

- 1) EUT and support equipment were set up on the turntable as per step 7 of the preliminary test.
- 2) The Analyzer / Receiver scanned from 30MHz to 1GHz. Emissions were scanned and measured rotating the EUT to 360 degrees, varying cable placement and positioning the antenna 1 to 4 meters above the ground plane, in both the vertical and the horizontal polarization, to maximize the mission reading level.
- 3) Recorded at least the six highest emissions. Emission frequency, amplitude, antenna position, polarization and turntable position were recorded into a computer in which correction factors were used to calculate the emission level and compare reading to the applicable limit and Q.P/Peak. Reading is presented.
- 4) The test data of the worst case condition(s) was reported on the Summary Data page.

Data Sample:

Freq. MHz	Amptd dBuV/m	Margin dB	Limit dBuV/m	Reading dBuV	Factor dB/m	Reading Type (P/Q/A)	Pol. (H/V)
x.xx	26.2	-13.8	40	14	12.2	Q	H

Freq. = Emission frequency in MHz
 Reading = Uncorrected Analyzer/Receiver reading
 Factor = Antenna Factor + Cable Loss + Attenuator (3/6/10dB) – Amplifier Gain
 Amptd = Uncorrected Analyzer/Receiver reading + Factor
 Limit = Limit stated in standard
 Margin = Reading in reference to limit
 P = Peak Reading
 Q = Quasi-peak Reading
 A = Average Reading
 H = Antenna Polarization: Horizontal
 V = Antenna Polarization: Vertical

Radiated Emission Limit

Frequency (MHz)	Distance (m)	Maximum Field Strength Limit (dBuV/m/ Q.P.)
30-230	3	40.00
230-1000	3	47.00

****Note:** The lower limit shall apply at the transition frequency.

12.3 Block Diagram of Test Setup

1) Block diagram of connection between the EUT and simulators

EUT: Prof Revolution S2 8000 PCI-E
TRADE NAME: N/A
MODEL NUMBER: Prof8000

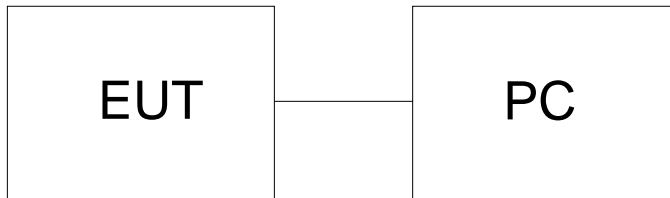

2) Block diagram of test setup in chamber

Radiated Emission Test

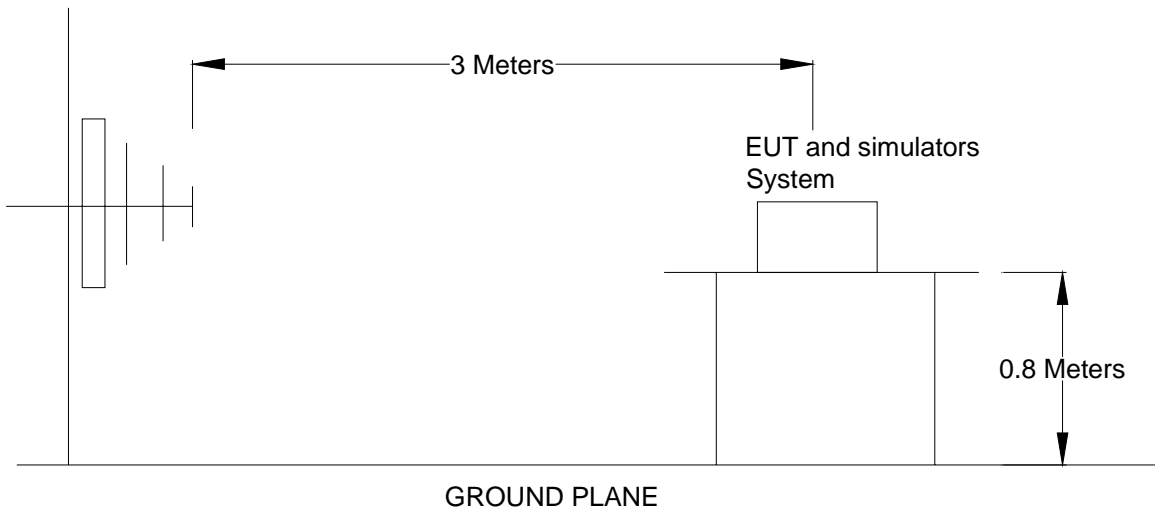



12.4 Summary Data

1) Radiated Emission Test

Model Number: Prof8000

Test Mode: DVB-S2

Test Results: Passed

Temperature: 26°C

Location: 966

Polar: Vertical/Horizontal

Test distance: 3m

Humidity: 60%RH

(All of the data and the waveforms are attached in appendix I, please refer to Appendix I for details.)

NOTE: 30MHz to 1000MHz test is Applicable EN 55013 standard.

13 HARMONIC CURRENT EMISSION TEST

13.1 POWER HARMONICS MEASUREMENT

Port :AC power port
Basic Standard :EN 61000-3-2:2006
Limits :Class A
Temperature :28°C
Humidity :55%

13.2 Block Diagram of Test Setup

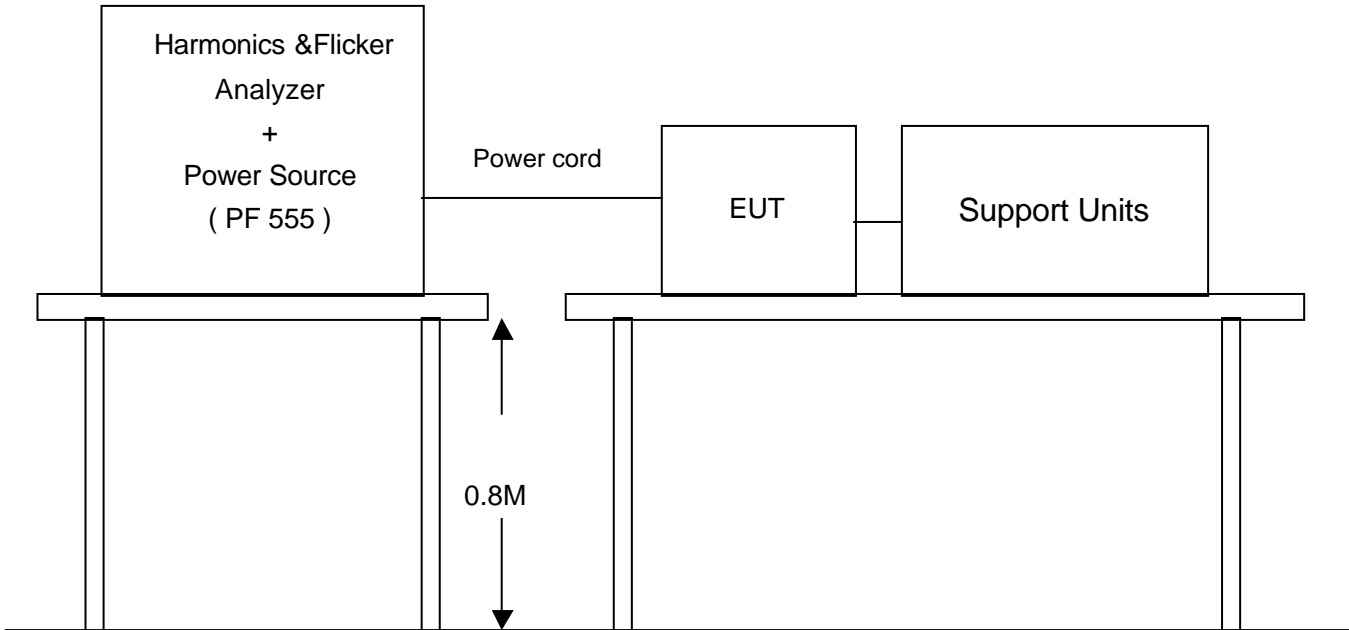

13.3 Result:

PASS

This item is not applicable since the EUT is powered by DC5V.

14 VOLTAGE FLUCTUATION/FLICKER

14.1 VOLTAGE FLUCTUATION/FLICKER MEASUREMENT

Port :AC power port
Basic Standard :EN 61000-3-3:2008
Limits :Table5 of EN 61000-3-3
Temperature :28°C
Humidity :55%

14.2 Block Diagram of Test Setup:

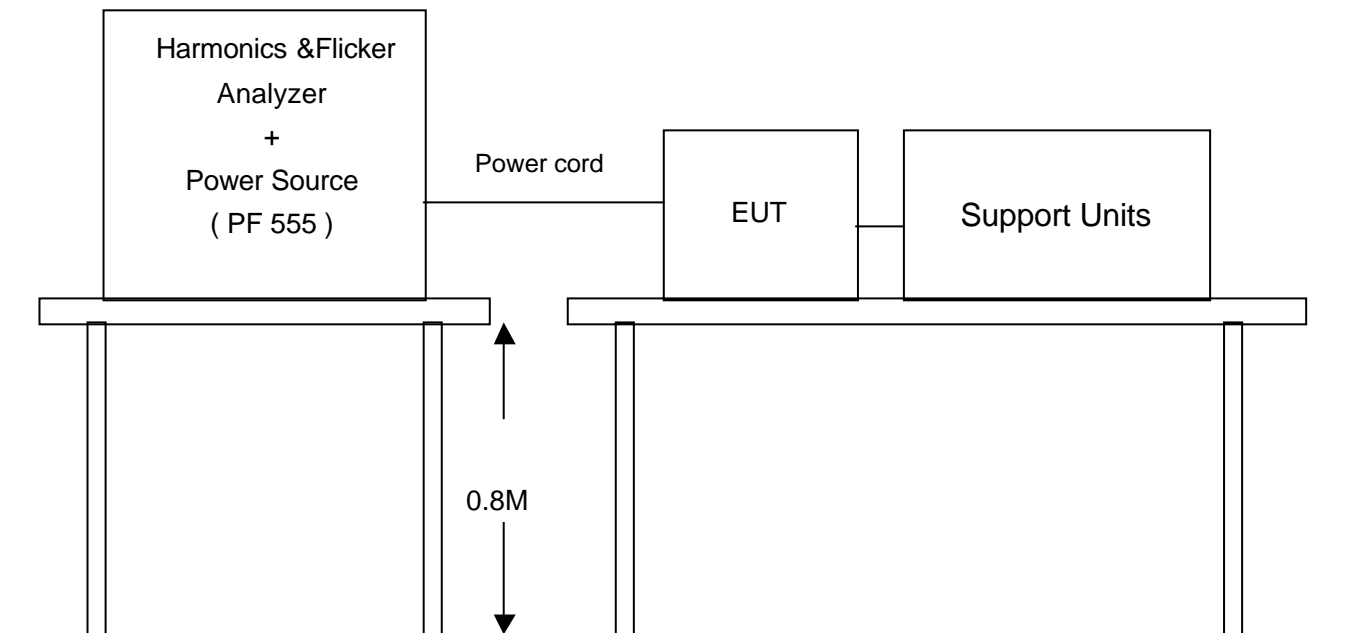

14.3 Result:

PASS

This item is not applicable since the EUT is powered by DC5V.

15 ELECTROSTATIC STATIC DISCHARGE TEST

15.1 ELECTROSTATIC DISCHARGE (ESD) IMMUNITY TEST

Port : Enclosure
 Basic Standard : EN 61000-4-2: 2009
 Test Level : $\pm 8\text{kV}$ (Air Discharge)
 $\pm 4\text{kV}$ (Contact Discharge)
 Performance Criteria : B (Standard require)
 Temperature : 22°C
 Humidity : 50%

15.2 Block Diagram of Test Setup

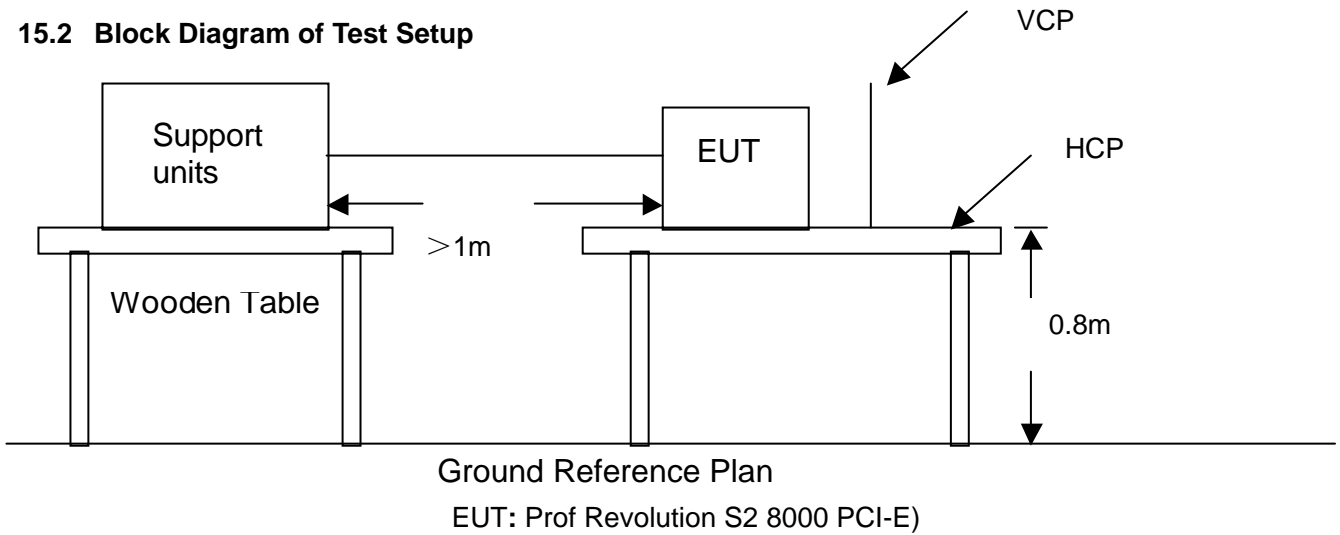

15.3 Severity Levels and Performance Criterion

Severity Level	Test Voltage Contact Discharge (kV)	Test Voltage Air Discharge (kV)
1	± 2	± 2
2	± 4	± 4
3	± 6	± 8
4	± 8	± 15
X	Special	Special



15.4 Test Procedure

1. For air discharge
This test is done a non-conductive surface. The round discharge tip of the discharge electrode shall be approached to the EUT as fast as possible. After each discharge, the ESD generator is then retriggered for a new single discharge (interval time between successive discharges is at least 1 second) and the discharge procedure is repeated 20 times (10 with positive and 10 with negative) for each reselected test point. This procedure shall be repeated until all the air discharge completed.
2. For contact discharge
Same as air discharge, except in the case of contact discharge, the tip of the discharge electrode shall touch conductive accessible pars of the EUT.
3. Indirect discharge for horizontal coupling plane
At least 20 single (10 times for positive and 10 times for negative) discharges shall be applied to the horizontal coupling plane, at points on each side of the EUT. The ESD generator positions vertically at a distance of 0.1 meter from the EUT and with the discharge electrode touching the coupling plane.
4. Indirect discharge for vertical coupling plane
At least 20 single discharges shall be applied to the center of one vertical edge of the coupling plane. The coupling plane, of dimensions 0.5m *0.5m, is placed parallel to, and positioned at a distance of 0.1 meter from the EUT. Discharges shall be applied to the coupling plane, with this plane in sufficient different positions that the four sides of the EUT are completely illuminated.

15.5 Performance & Result:

- Criteria A:** The apparatus continues to operate as intended. No degradation of performance or loss of function is allowed below a performance level specified by the manufacturer, when the apparatus is used as intended. In some cases the performance level may be replaced by a permissible loss of performance.
- Criteria B:** The apparatus continues to operate as intended after the test. No degradation of performance or loss of function is allowed below a performance level specified by the manufacturer, when the apparatus is used as intended. In some cases the performance level may be replaced by a permissible loss of performance. During the test, degradation of performance is however allowed.
- Criteria C:** Temporary loss of function is allowed, provided the functions self-recoverable or can be restored by the operation of controls.

<input checked="" type="checkbox"/> PASS	<input type="checkbox"/> FAILED
---	--

Please refer to the following page



Electrostatic Discharge Test Results

Applicant	: HongKong Tenow International Ltd.	Test Date	: 2010-4-30
EUT	: Prof Revolution S2 8000 PCI-E	Temperature	: 22°C
Model No	: Prof8000	Humidity	: 50%
Air discharge	: ±8Kv	Test Mode	: ON
Contact discharge	: ±4Kv	Criterion	: B
Test Engineer	: John		
	Location	Kind A-Air Discharge C-Contact Discharge	Result
	HCP	C	PASS
	VCP	C	PASS
	PORT	C	PASS
	SLOT	C	PASS
Note:			
Test Equipment: HAEFELY ESD TESTER Model: PESD 1600			

16 RADIATED ELECTROMAGNETIC FIELD

16.1 Radiated Electromagnetic Field Immunity Test

Port	: Exposure
Basic Standard	: EN 61000-4-3:2006
Requirements	: 3V/m with 80% AM. 1 KHz Modulation
Performance Criteria	: A (Standard require)
Temperature	: 28°C
Humidity	: 55%

16.2 Block Diagram of Test Setup

7x3x3 Chamber

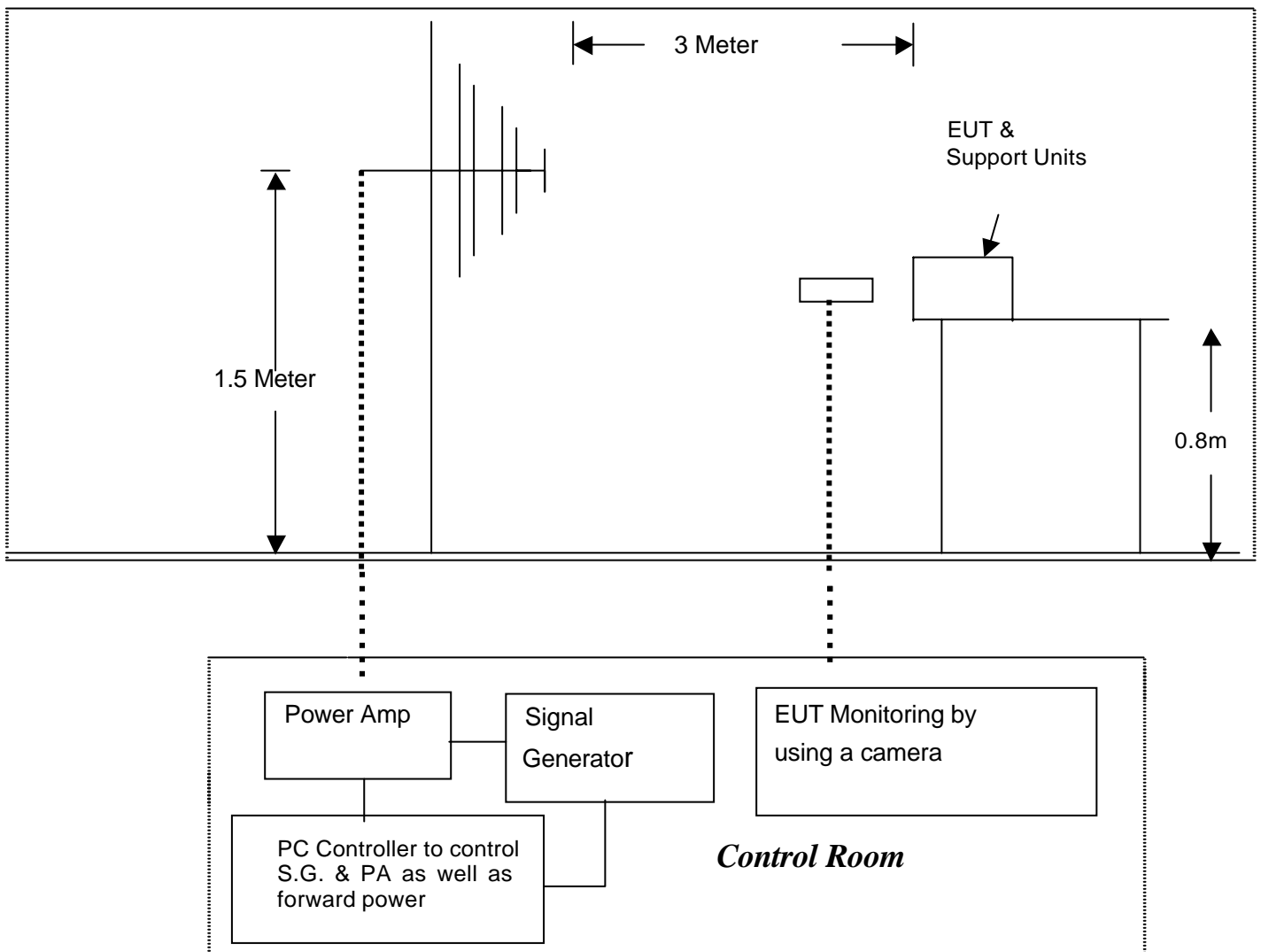



16.3 Test Procedure

1. The EUT and support units were located at the edge of supporting table keep 3 meter away from transmitting antenna, it just the calibrated square area of field uniformity.
2. Adjusting the cables to be exposed to the electromagnetic filed as possible.
3. Performing a Radiated Emission Scan in range of 30 to 1000 MHz prior to do RS test and records the more higher emission frequencies for the reference of RS test, due to antenna effectiveness.
4. Adjusting the monitoring camera to monitor the multi-meter scale as clear as possible.
5. Setting the testing parameters of RS test software per IEC 61000-4-3.
6. Referring to the tested data of step 3 to performing the RS test from 80 to 1000 MHz.
7. Recording the test result in following table.
8. Changing the EUT to the other side and repeat step 3 to 6, until 4 sides of EUT were verified.

IEC61000-4-3 test conditions

Test level : 3V/m
Steps : 1% of fundamental
Dwell Time : 1 sec

Range(MHz)	Field	Modulation	Polarity	Position(°)	Result(Pass/Fail)
80-1000	3V/m	Yes	H	Front	Pass
80-1000	3V/m	Yes	V	Front	Pass
80-1000	3V/m	Yes	H	Right	Pass
80-1000	3V/m	Yes	V	Right	Pass
80-1000	3V/m	Yes	H	Back	Pass
80-1000	3V/m	Yes	V	Back	Pass
80-1000	3V/m	Yes	H	Left	Pass
80-1000	3V/m	Yes	V	Left	Pass

16.4 : Performance & Result

- Criteria A:** The apparatus continues to operate as intended. No degradation of performance or loss of function is allowed below a performance level specified by the manufacturer, when the apparatus is used as intended. In some cases the performance level may be replaced by a permissible loss of performance.
- Criteria B:** The apparatus continues to operate as intended after the test. No degradation of performance or loss of function is allowed below a performance level specified by the manufacturer, when the apparatus is used as intended. In some cases the performance level may be replaced by a permissible loss of performance. During the test, degradation of performance is however allowed.
- Criteria C:** Temporary loss of function is allowed, provided the functions self-recoverable or can be restored by the operation of controls.

<input checked="" type="checkbox"/> PASS	<input type="checkbox"/> FAILED
---	--

17 FAST TRANSIENTS/BURST

17.1 Fast Transients/Burst Immunity Test

Port	: AC Power Line
Basic Standard	: EN 61000-4-4:2004
Requirements	: +/- 1kV for Power Supply Lines
Performance Criteria	: A (Standard require)
Temperature	: 25°C
Humidity	: 55%

15.2 Block Diagram of Test Setup

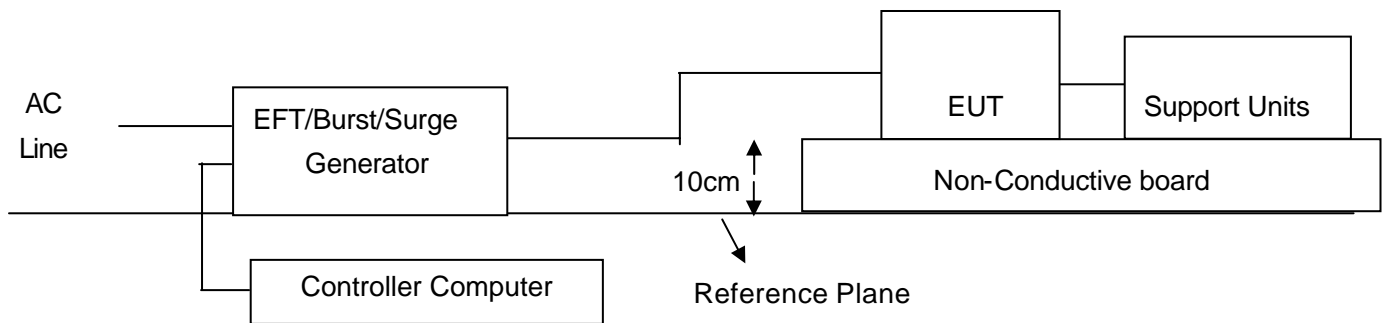



17.2 Test Procedure

1. The EUT and support units were located on a wooden table 0.8 m away from ground reference plane.
2. A 1.0 meter long power cord was attached to EUT during the test.
3. The length of communication cable between communication port and clamp was keeping within 1 meter.
4. Set up EUT with the relative support equipments and power on. Make sure the EUT works normally during the test.
5. Related peripherals work during the test.
6. Recording the test result as shown in following table.

Test conditions:

Impulse Frequency: 5kHz

Tr/Th: 5/50ns

Burst Duration: 15ms

Burst Period: 3Hz

Inject Line	Voltage kV	Inject Method	Result (Pass/Fail)
L1	+/- 1	Direct	Pass
N	+/- 1	Direct	Pass
L1+N	+/- 1	Direct	Pass

17.3 Performance & Result:

- Criteria A:** The apparatus continues to operate as intended. No degradation of performance or loss of function is allowed below a performance level specified by the manufacturer, when the apparatus is used as intended. In some cases the performance level may be replaced by a permissible loss of performance.
- Criteria B:** The apparatus continues to operate as intended after the test. No degradation of performance or loss of function is allowed below a performance level specified by the manufacturer, when the apparatus is used as intended. In some cases the performance level may be replaced by a permissible loss of performance. During the test, degradation of performance is however allowed.
- Criteria C:** Temporary loss of function is allowed, provided the functions self recoverable or can be restored by the operation of controls.

<input checked="" type="checkbox"/> PASS	<input type="checkbox"/> FAILED
---	--

NOTE: This item is not applicable since the EUT is powered by DC5V.



APPENDIX I-RADIATED EMISSION TEST DATA



No.	Mk.	Freq. MHz	Reading Level dBuV	Correct Factor dB	Measure- ment dBuV/m	Limit dBuV/m	Over dB	Detector	Antenna Height cm	Table Degree degree	Comment
1		95.2883	20.00	13.15	33.15	40.00	-6.85	QP			
2	*	392.1954	23.40	16.85	40.25	47.00	-6.75	QP			
3		874.0865	16.60	23.22	39.82	47.00	-7.18	QP			

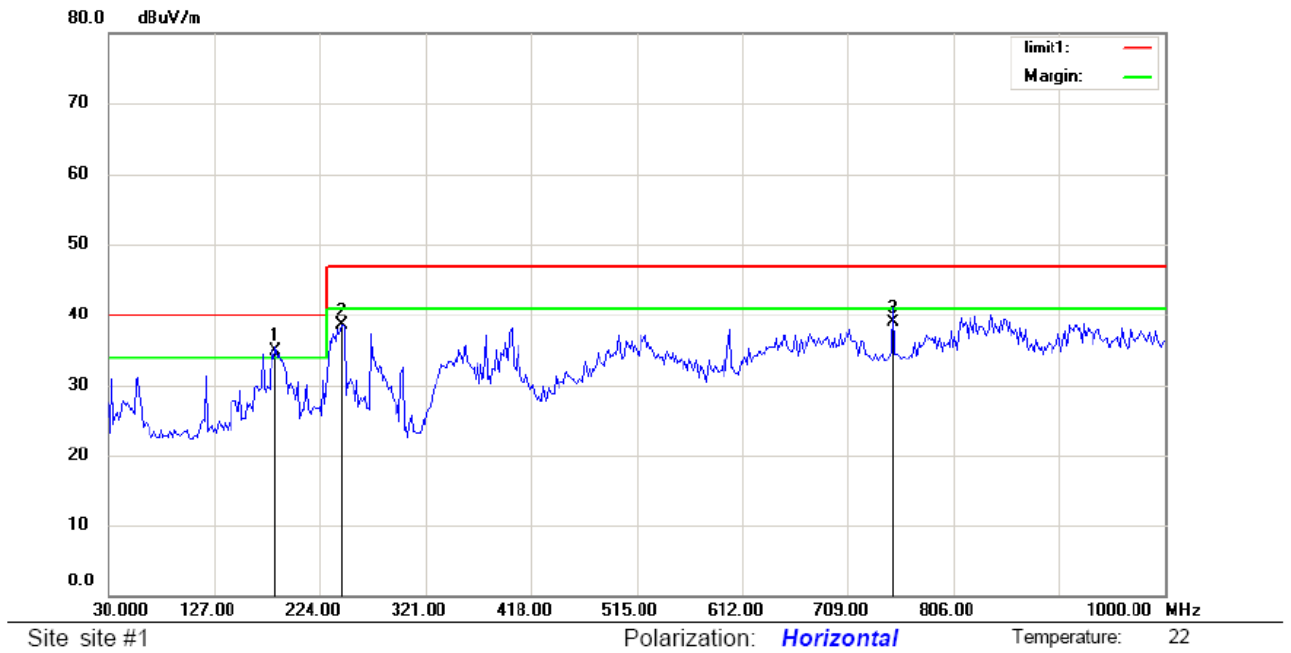

No.	Mk.	Freq. MHz	Reading Level dBuV	Correct Factor dB	Measure- ment dBuV/m	Limit dBuV/m	Over dB	Detector	Antenna Height cm	Table Degree degree	Comment
1	*	183.8942	24.30	10.51	34.81	40.00	-5.19	QP			
2		244.5192	25.20	13.37	38.57	47.00	-8.43	QP			
3		751.2820	15.90	22.99	38.89	47.00	-8.11	QP			

APPENDIX II- PHOTOGRAPHS OF TEST

1) Photo of Radiated Emission Test



2) Photo of ESD Test.





3) Photo of Radiated Electromagnetic Field Test



APPENDIX III- PHOTOGRAPHS OF THE EUT

Photo 1

View: Prof8000

- front
- rear
- right side
- left side
- top
- bottom
- internal



Photo 2

View: Prof8000

- front
- rear
- right side
- left side
- top
- bottom
- internal

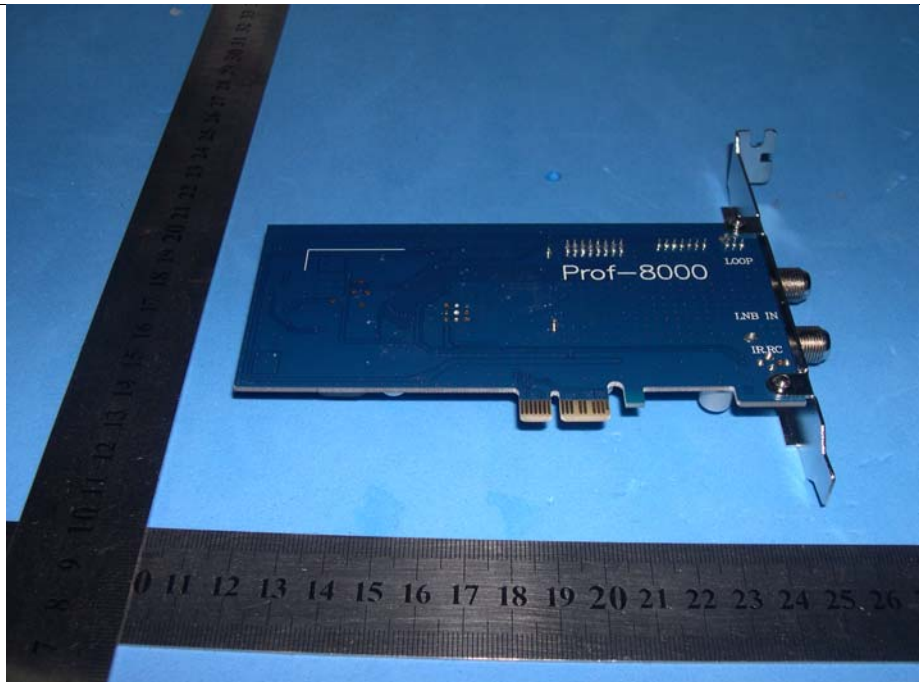

Photo 3

View: Prof8000

- front
- rear
- right side
- left side
- top
- bottom
- internal

